

KOMATSU®

PC130-7

NET HORSEPOWER
66 kW 88 HP @ 2.200 rpm

OPERATING WEIGHT
13.000 kg

BUCKET CAPACITY
max. 0,8 m³

PC
130

HYDRAULIC EXCAVATOR



PC130-7

WALK-AROUND

The PC130-7 is a rugged, productive, all-European machine. Designed and expressly built for European markets, it delivers productivity, reliability and operator comforts in a robust, environmentally-friendly package. Komatsu's exclusive, on-board, HydraulMind system assists in all operations, providing enhanced machine performance that's always perfectly matched to the task.

What's new on Dash 7:

- Higher stability
- Low fuel consumption
- Easier maintenance and serviceability
- Improved operator comfort
- Lower noise
- Meets EC Stage II emission regulations

High productivity and low fuel consumption

The powerful turbocharged and air-to-air aftercooled Komatsu SAA4D95LE-3 provides 66 kW/88 HP.

Productivity has increased with greater output in the 'Active' mode, while fuel efficiency has been further improved.

Flexibility

The PC130-7 is standard equipped with an additional circuit to handle a wide variety of attachments.

High stability

Lateral stability and lifting capacity have been improved by increasing the track length on ground and the width of gauge, compared to the Dash 6 model.

Excellent reliability and durability

- Reinforced work equipment
- Reliable major components designed and built by Komatsu
- Exceptionally-reliable electronic devices



NET HORSEPOWER
66 kW 88 HP

OPERATING WEIGHT
13.000 kg

BUCKET CAPACITY
max. 0,8 m³

Easy maintenance

- Remote-mounted engine oil filter, for easy access
- Standard-equipped water separator
- Easier radiator cleaning due to new side-by-side oil cooler and radiator

SpaceCab™

The new PC130-7's cabin space has been increased by 14%, offering an exceptionally-roomy operating environment.

- Sealed and pressurised cab with standard climate control
- Low-noise design
- Low-vibration design with cabin damper mounting
- OPG Level I (ISO) compliant cabin

In harmony with the environment

- The low emission engine meets EC Stage II emissions standards with increased power and machine productivity
- The economy mode reduces fuel consumption
- Low operating noise
- Designed for easy end-of-life recycling



WORKING ENVIRONMENT

PC130-7's cab interior is spacious and provides a comfortable working environment...

SpaceCab™

Comfortable cab

The new PC130-7 inner cab volume is 14% greater than the Dash 6, offering an exceptionally comfortable operating environment. The large cab enables the seat, with headrest, to be reclined to horizontal.

Pressurised cab

The standard-equipped climate control, air filter and a higher internal air pressure resist dust entry into the cab.

Low-noise design

Noise levels are substantially reduced; engine noise as well as swing and hydraulics operations noise.

Cab damper mounting for low vibration levels

PC130-7 uses a new and improved viscous damping cab mount system that incorporates a longer stroke plus an added spring. The new cab damper mounting, combined with strengthened left and right-side decks, aids the reduction of vibrations to the operator's seat.



Outer air filter

Easy removal/installation of the air conditioner filter element, without tools facilitates easier cleaning.

Riding comfort comparison

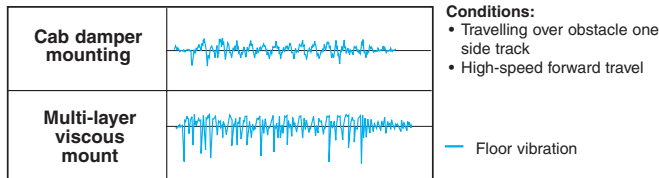

Vertical pitch oscillation on the graph shows the intensity of vibration

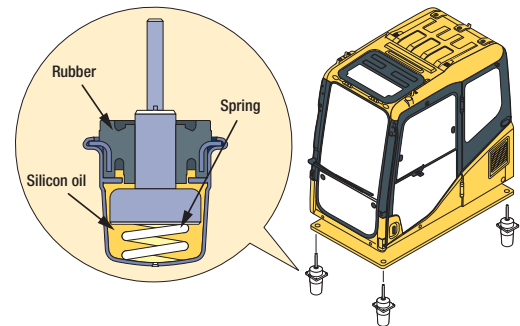

Roof hatch



12-Volt power supply



Climate control



Bottle holder and magazine rack

Safety features

Multi-position controls

The multi-position, proportional pressure control levers allow the operator to work in comfort whilst maintaining precise control. A double-slide mechanism allows the seat and controllers to move together, or independently, allowing the operator to position the controllers for maximum productivity and comfort.



Hot and cool box



3 button lever



Seat sliding range: 340 mm – increased by 120 mm over the Dash 6



Defroster/demister

Improved, wide visibility

The right side window pillar has been removed and the rear pillar reshaped to provide greater visibility. Blind spots have been decreased by 34%.

Pump/engine room partition

This prevents hydraulic oil from spraying onto the engine to reduce the risk of fire.

Thermal and fan guards

Are placed around high-temperature parts of the engine. The fan belt and pulleys are well protected.

Steps with non-skid surface and large handrail

Steps with non-slip surfacing ensure safer maintenance.

Thermal guard



Non-slip sheet



Large handrail for safe access



PRODUCTIVITY FEATURES

Engine

The PC130-7 gets its exceptional power and work capacity from a Komatsu SAA4D95LE-3 engine. Its output is 66 kW/88 HP, providing increased hydraulic power and improved fuel efficiency.



High production levels and low fuel consumption

The increased output and fuel savings of the Komatsu SAA4D95LE-3 engine result in increased productivity (tonnes per litre of fuel).

OPG top and front guard

The optional bolt-on OPG (Operation Protection Guard) top guard and front guard are available for operations in jobsites where there is high possibility of falling rocks or debris. OPG level 2 for top and front guard according to ISO 10262.



Self-diagnostic monitor system

The PC130-7 features one of the most advanced diagnostic systems in the industry. Komatsu's exclusive system identifies maintenance items, reduces diagnostic time, and helps you maintain maximum production.

Working mode	Application	Advantage
A	Active mode	<ul style="list-style-type: none"> • Maximum production/power • Fast cycle times
E	Economy mode	<ul style="list-style-type: none"> • Excellent fuel economy
B	Breaker mode	<ul style="list-style-type: none"> • Optimum engine RPMs and hydraulic flow
L	Lifting mode	<ul style="list-style-type: none"> • Hydraulic pressure has been increased by 7%

A Engine water temperature

B Battery charge

C Engine oil pressure

D Air cleaner clogging

E Auto deceleration

F Travel speed selector switch

G Working mode selector switch

H Fuel level

I User or trouble code display

J Service hours meter

K Engine oil level

L Pre-heat

M Swing lock display

N Oil maintenance

O Window wiper

P Window washer

H

I

J

K

L

M

N

O

P

Excellent reliability and durability

Reliable components

All of the major machine components, such as the engine, hydraulic pump, hydraulic motor and control valves, are designed and manufactured by Komatsu. This guarantees that each component is expressly built for the class and model of machine. This ensures that the engineering, manufacturing standards and testing that go into each component are 'totally-Komatsu'.

Sturdy frame structure

The revolving frame, centre frame and undercarriage have been designed using the most advanced three-dimensional Computer Aided Design (CAD) and Finite Elements Modelling (FEM) analysis technology.

Highly-reliable electronic devices

Exclusively-designed electronic devices are certified by severe testing.

- Controller
- Sensors
- Connectors
- Heat-resistant wiring

Metal guard rings

These protect all hydraulic cylinders and improve reliability.

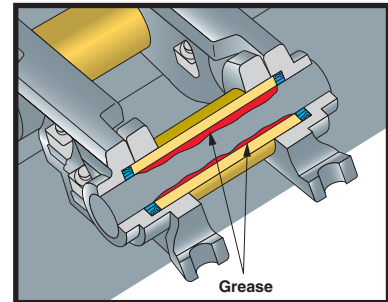

Grease-sealed track provides excellent undercarriage durability



Track link with strut
The PC130-7 uses track links with struts, providing superb durability

Harmony with the environment

Low-emission engine

Komatsu SAA4D95LE-3 is EC Stage II compliant, with reduced NOx emissions, compared to the PC130-6.

Economy (environment) mode

'Economy' mode meets the needs of the 21st century. This mode offers the user fuel savings, quiet operation, and less CO₂ emissions.

Low noise

Noise has been reduced from the engine as well as from swing and hydraulic operations. The dynamic noise level is just 73 dB(A) at operator ear level (ISO 6369).

Easy end-of-life recycling

The PC130-7 is designed with the consideration of end-of-life recycling, effectively reducing its environmental impact.

- All exterior parts are made of steel.
- Extended engine oil, hydraulic oil and filter replacement intervals reduce environmental impact.
- All plastic parts are given a material code symbol.

MAINTENANCE FEATURES

Easy maintenance

Komatsu designed the PC130-7 to have easy service access. By doing this, routine maintenance and servicing are less likely to be skipped. This can mean a reduction in costly downtime later on. Here are some of the many service features found on the PC130-7:

Side-by-side cooling

Since radiator, aftercooler and oil cooler are arranged in parallel, it is easy to clean, remove and install them.



Water separator

This is standard equipment which removes any water that has become mixed with the fuel, preventing fuel system damage.



Easy access to the engine oil filter

The engine oil filter is mounted remotely to improve accessibility.



SPECIFICATIONS



ENGINE

Model..... Komatsu SAA4D95LE-3
 Type..... Direct injection, water-cooled, emissionised, turbocharged, after-cooled diesel
 Rated capacity..... 66 kW/88 HP (ISO 9249 Net) at engine speed2.200 rpm
 No. of cylinders 4
 Bore x stroke95 x 115 mm
 Displacement..... 3,26 ltr
 Battery..... 2 x 12 V/65 Ah
 Alternator..... 24 V/25 A
 Starter motor 24 V/3,0 kW
 Air filter type.....Double element type with monitor panel dust indicator and auto dust evacuator



SWING SYSTEM

Type..... Hydrostatic
 Swing lockMechanical disc brake
 Swing speed.....0 - 11 rpm



DRIVES AND BRAKES

Steering control 2 levers with pedals giving full independent control of each track
 Drive method Hydrostatic
 Travel operation Automatic 2-speed selection
 Gradeability 70%, 35°
 Max. travel speeds
 Lo / Hi..... 2,7 / 5,5 km/h



HYDRAULIC SYSTEM

Type..... HydrauMind. Closed-centre system with load sensing and pressure compensation valves
 Additional circuits.....1 additional circuit is standard
 Main pump.....variable displacement piston pump supplying boom, arm, bucket, swing and travel circuits
 Maximum pump flow..... 312 ltr/min
 Relief valve settings
 Implement 325 kg/cm²
 Travel..... 355 kg/cm²
 Swing..... 295 kg/cm²
 Pilot circuit..... 30 kg/cm²



UNDERCARRIAGE

ConstructionX-frame centre section with box section track-frames
 Track assembly
 Type..... Fully sealed
 Shoes (each side) 43
 Tension..... Combined spring and hydraulic unit
 Rollers
 Track rollers (each side) 7
 Carrier rollers (each side) 1



COOLANT AND LUBRICANT CAPACITY (REFILLING)

Fuel tank..... 247 ltr
 Radiator..... 13,4 ltr
 Engine oil..... 11,0 ltr
 Swing drive 2,5 ltr
 Hydraulic tank..... 90 ltr
 Final drive (each side) 2,5 ltr



OPERATING WEIGHT (APPR.)

Operating weight, including 4.600 mm one-piece boom, 2,5 m arm, 470 kg bucket, operator, lubricant, coolant, full fuel tank and the standard equipment.



ENVIRONMENT

Engine emissions Fully complies with EC Stage II exhaust emission regulations
 Noise levels
 LwA external 102 dB(A) (2000/14/EC)
 LpA operator ear 73 dB(A) (ISO 6369 dynamic test)

MONO BOOM		
PC130-7		
Triple grouser shoes	Operating weight	Ground pressure
500 mm	12.600 kg	0,39 kg/cm ²
600 mm	12.780 kg	0,34 kg/cm ²
700 mm	12.960 kg	0,30 kg/cm ²

MACHINE DIMENSIONS

MACHINE DIMENSIONS		PC130-7
A	Overall width of upper structure	2.490 mm
B	Overall height of cab	2.810 mm
C	Overall length of basic machine	3.925 mm
D	Tail length	2.110 mm
	Tail swing radius	2.190 mm
E	Clearance under counterweight	855 mm
F	Machine tail height	1.885 mm
G	Ground clearance	400 mm
H	Track length on ground	2.880 mm
I	Track length	3.610 mm
J	Track gauge	1.990 mm
K	Track shoe width	500, 600, 700 mm
L	Overall track width with 500 mm shoe	2.490 mm
	Overall track width with 600 mm shoe	2.590 mm
	Overall track width with 700 mm shoe	2.690 mm

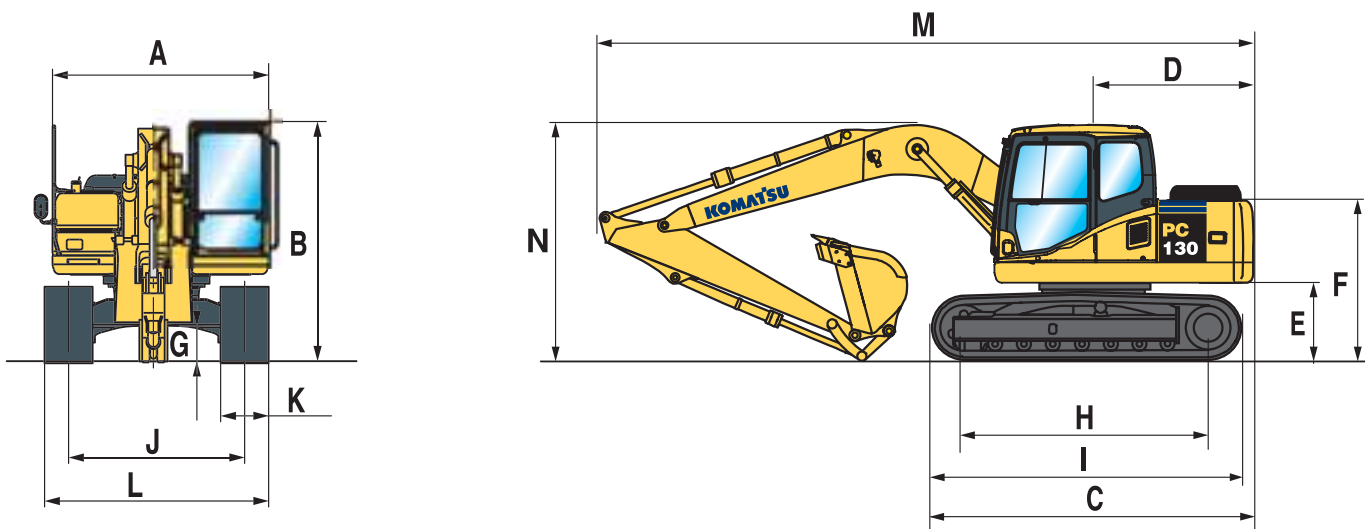

ARM LENGTH		MONO BOOM		
		2.100 mm	2.500 mm	2.900 mm
M	Transport length	7.590 mm	7.595 mm	7.510 mm
N	Overall height (to top of boom)	2.620 mm	2.175 mm	3.075 mm

BUCKET OPTIONS & DIGGING FORCES

Specifications and equipment may vary according to regional availability

PC130-7

BUCKET AND ARM COMBINATION			PC130-7		
Width	Capacity SAE	Weight	2.100 mm	2.500 mm	2.900 mm
500 mm	0,25 m ³	325 kg	○	○	○
600 mm	0,32 m ³	350 kg	○	○	○
700 mm	0,40 m ³	390 kg	○	○	○
800 mm	0,48 m ³	440 kg	○	○	○
900 mm	0,56 m ³	475 kg	○	○	□
1.000 mm	0,64 m ³	505 kg	○	□	□
1.100 mm	0,72 m ³	560 kg	□	△	△
1.200 mm	0,80 m ³	620 kg	△	–	–

Please consult with your distributor for the correct selection of buckets and attachments to suit the application. The recommendations are given as a guide only, based on typical operating conditions.

- Material weight up to 1,8 t/m³
- Material weight up to 1,5 t/m³
- △ Material weight up to 1,2 t/m³
- Not usable

BUCKET AND ARM FORCE			
Arm length	2.100 mm	2.500 mm	2.900 mm
Bucket digging force (ISO)	8.800 kgf	8.800 kgf	8.800 kgf
Bucket digging force at power max. (ISO)	9.500 kgf	9.500 kgf	9.500 kgf
Arm crowd force (ISO)	7.200 kgf	6.300 kgf	5.700 kgf
Arm crowd force at power max. (ISO)	7.900 kgf	6.900 kgf	6.200 kgf

WORKING RANGES

MONO BOOM

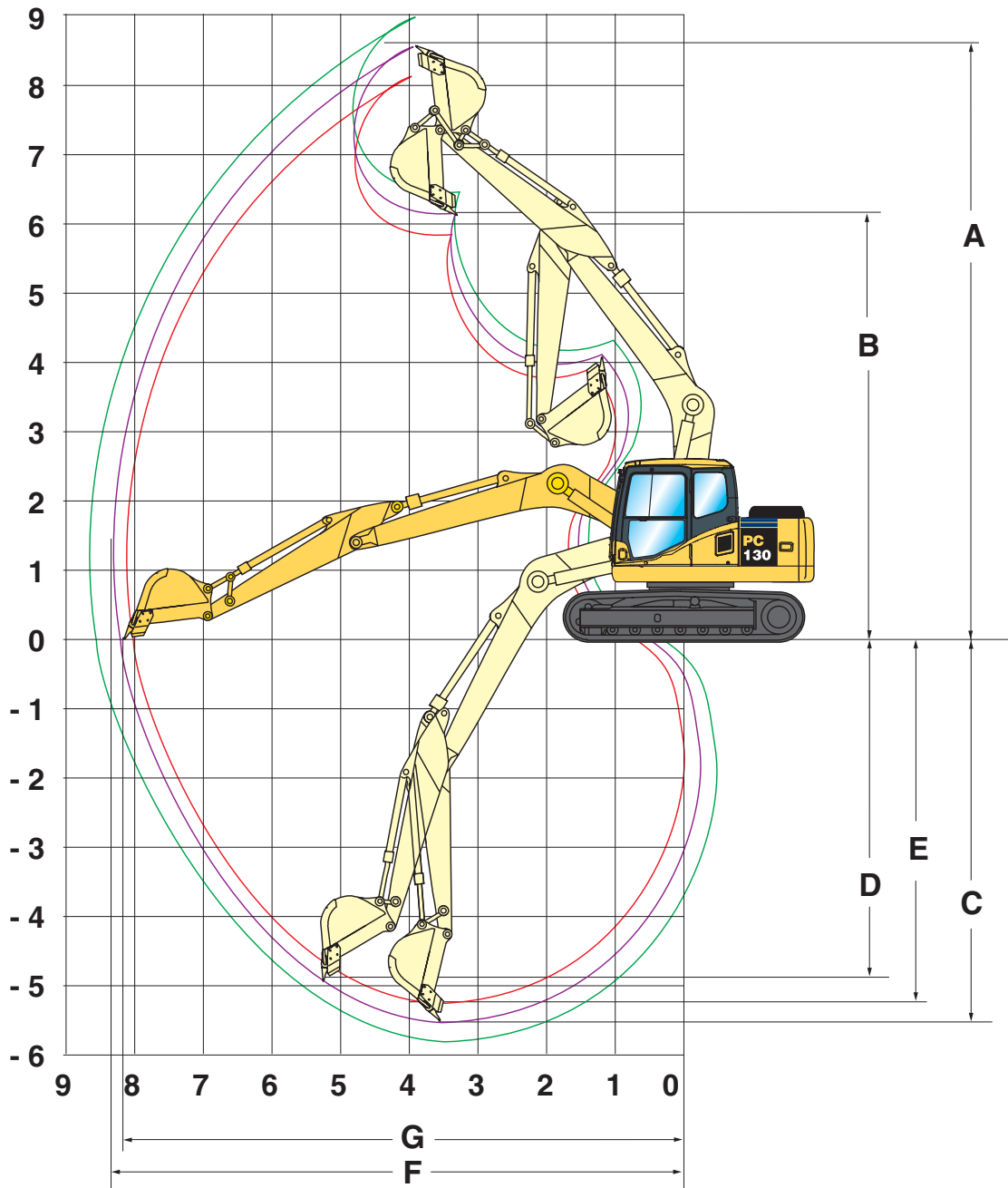

ARM LENGTH		2.100 m	2.500 mm	2.900 mm
A	Max. digging height	8.345 mm	8.610 mm	8.970 mm
B	Max. dumping height	5.905 mm	6.170 mm	6.535 mm
C	Max. digging depth	5.115 mm	5.520 mm	6.015 mm
D	Max. vertical wall digging depth	4.520 mm	4.940 mm	5.360 mm
E	Max. digging depth of cut for 2,44 m level	4.875 mm	5.315 mm	5.835 mm
F	Max. digging reach	7.925 mm	8.290 mm	8.785 mm
G	Max. digging reach at ground level	7.795 mm	8.170 mm	8.665 mm

LIFTING CAPACITY

PC130-7 MONO BOOM

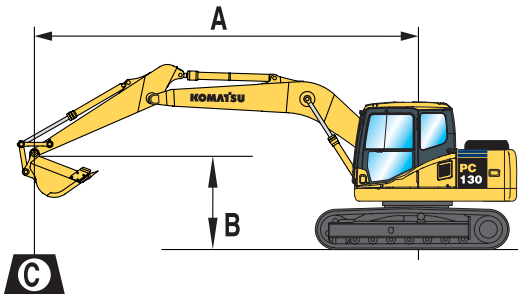

- A** – Reach from swing center
 - B** – Bucket hook height
 - C** – Lifting capacities, including bucket (469 kg), bucket linkage (120 kg) and bucket cylinder (83 kg)
- Rating over front
 - Rating over side
 - Rating at maximum reach

When removing bucket, linkage or cylinder, lifting capacities can be increased by their respective weights

With 700 mm shoe

Arm length	A			7,5 m		6,0 m		4,5 m		3,0 m		1,5 m	

With 700 mm shoe	6,0 m	kg	*2.400	*2.400			*3.400	*3.400					
	4,5 m	kg	*2.250	2.000		2.950	2.200	*3.550	*3.550				
	3,0 m	kg	*2.250	1.700		2.950	2.150	*4.350	3.450	*6.000	*6.000		
	1,5 m	kg	2.200	1.550		2.850	2.050	4.550	3.250	*8.550	6.000		
	0,0 m	kg	2.250	1.600		2.750	2.000	4.250	3.050	*7.400	5.650		
	-1,5 m	kg	2.550	1.800		2.750	1.950	4.150	3.000	8.750	5.600	*4.750	*4.750
	-3,0 m	kg	3.300	2.350				4.300	3.000	*7.550	5.750	*8.800	*8.800
	-4,5 m	kg											

With 700 mm shoe	6,0 m	kg	*1.950	*1.950										
	4,5 m	kg	*1.800	1.700		3.000	2.250	*3.150	*3.150					
	3,0 m	kg	*1.850	1.550	2.250	1.650	2.950	2.200	*3.950	3.550	*5.200	*5.200		
	1,5 m	kg	*1.950	1.450	2.200	1.600	2.850	2.100	4.550	3.300	*7.900	6.150		
	0,0 m	kg	2.050	1.450	2.150	1.550	2.750	2.000	4.250	3.000	*8.050	5.700		
	-1,5 m	kg	2.250	1.600			2.700	1.950	4.250	3.000	8.700	5.600	*4.700	*4.700
	-3,0 m	kg	2.850	2.050					4.250	2.950	*8.050	5.700	*7.850	*7.850
	-4,5 m	kg	*3.600	3.200							*5.450	*5.450		

With 700 mm shoe	6,0 m	kg	*1.550	*1.550		*2.200	2.250							
	4,5 m	kg	*1.450	1.450	*1.950	1.650	*2.750	2.250						
	3,0 m	kg	*1.450	1.350	2.200	1.650	2.950	2.200	*3.450	*3.450				
	1,5 m	kg	*1.550	1.250	2.150	1.550	2.800	2.050	*4.550	3.300	*6.800	6.250		
	0,0 m	kg	*1.750	1.250	2.100	1.500	2.700	1.950	4.300	3.050	8.800	5.650		
	-1,5 m	kg	1.950	1.350	2.050	1.450	2.650	1.850	4.050	2.900	8.550	5.450	*4.100	*4.100
	-3,0 m	kg	2.350	1.650			2.600	1.850	4.050	2.900	*8.450	5.500	*6.650	*6.650
	-4,5 m	kg	*3.400	2.450					*4.200	3.000	*6.500	5.650	*10.350	*10.350

* Load is limited by hydraulic capacity rather than tipping.
 Ratings are based on SAE Standard No. J1097.
 Rated loads do not exceed 87% of hydraulic lift capacity or 75% of tipping load.

HYDRAULIC EXCAVATOR



STANDARD EQUIPMENT

- Komatsu SAA4D95LE-3 66 kW direct injection emissionised Stage II intercooled turbocharged engine
- Double element type air cleaner with dust indicator and auto-dust evacuator
- Automatic fuel line de-aeration
- Engine key stop
- Alternator 24 V/25 A
- Batteries 2 × 12 V/65 Ah
- Starter motor 24 V/3,0 kW
- Electronic closed-centre load sensing (E-CLSS) hydraulic system (HydrauMind)
- Pump and engine mutual control (PEMC) system
- 4-working mode selection system; Active mode, economy mode, breaker mode and lifting mode
- Standard counterweight
- PowerMax function
- Auto-deceleration function
- Automatic engine warm-up system
- Engine overheat prevention system
- Fuel control dial
- PPC control levers and pedals for steering and travel
- One additional service valve (full flow)
- Hydrostatic, 2-speed travel system with automatic shift and planetary gear type final drives, and hydraulic lock service brakes
- SpaceCab™; Highly pressurised and tightly sealed viscous mounted cab with tinted safety glass windows, opening roof hatch with window pull-up type front window with locking device, removable lower window, front window wiper with intermittent feature, ashtray, luggage box, floor mat
- Parts book and operator manual
- Lockable fuel cap and covers
- Fuel supply pump
- Track frame under-guards
- 12 Volt power supply
- Overload warning device
- Boom safety valves
- Climate control/Air conditioning
- Large handrails and rear-view mirrors
- Cigarette lighter
- Radio cassette preparation
- Beverage holder and magazine rack
- Electric horn
- Hot and cool box
- Toolkit and spare parts for first service
- Suspension seat with adjustable arm rests and retractable seat belt
- Standard colour scheme and decals
- 500 mm triple grouser track-shoes

OPTIONAL EQUIPMENT

- 600 mm; 700 mm triple grouser track-shoes
- Mono boom
- Two-piece boom
- 2,1 m; 2,5 m; 2,9 m arms
- Blade assembly
- OPG Level II top guard (FOPS)
- OPG Level II front guard (FOPS)
- Radio cassette
- Service points
- Beacon preparation
- Bio oil
- Additional cab roof lights
- Additional boom light
- Rain visor (not with OPG)
- Komatsu buckets
- Arm safety valve
- Customised paint
- Track roller guards
- Larger alternator
- High capacity batteries

KOMATSU®

**Komatsu Europe
International NV**

Mechelsesteenweg 586
B-1800 VILVOORDE (BELGIUM)
Tel. +32-2-255 24 11
Fax +32-2-252 19 81
www.komatsueurope.com

UESS001200 05/2004

Materials and specifications are subject to change without notice.

KOMATSU® is a trademark of Komatsu Ltd. Japan.