

Compaction Rollers (Walk Behind)

OPERATING WEIGHT	512 kg
GROSS ENGINE POWER	5.5 kW (7.4 hp)
DRUM WIDTH	710 mm
STATIC LINEAR LOAD	7.2 kg/cm
CENTRIFUGAL FORCE	9.0 kN



COMPACTION ROLLERS

- Single Drum
- Drum widths from 650mm to 710mm - Operating weight of 512 kg.
- Powerful and reliable air cooled engines, with hydrostatic transmission for power.
- Superb service access and easy to service components.
- High quality heavy duty design with in-built vandal protection - "rental tough".
- Heavy duty vibration system with high centrifugal force, frequency and static linear load reduces the number of passes required.
- Ergonomic control lever for simple and easy operation of all functions.

Specifications (Performance)		
	MBR71	
Total Static Basic Weight (kg)	500	
Operating Weight (kg) CECE	512	
Static Linear load (kg/cm)	7.2	
Frequency - Hz (VPM)	65 (3900)	
Amplitude (mm)	0.66	
Centrifugal Force (kN)	9.0	



TEREX

Compaction Rollers (Walk Behind)

MBR71

Dimensions

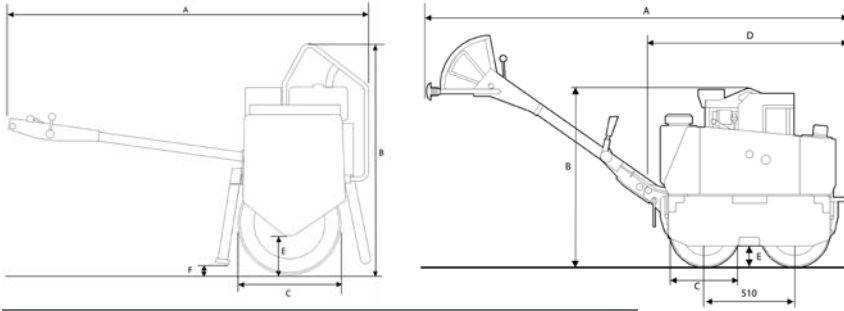

Dimensions (mm)

	MBR71
A - Overall Length (mm)	2180
B - Overall Height (mm)	1300
C - Drum Diameter (mm)	575
D - Folded Length (mm)	n/a
E - Curb Clearance (mm)	230
F - Ground Clearance (mm)	170
Overhang - Left / Right (mm)	20/110
Drum Width (mm)	710
Drum Shell Thickness (mm)	8.0

Engine & Drive

	MBR71
Engine Make	Hatz
Engine Model	1D41S
Cylinders	1
Displacement (cc)	413
Cooling	Air
Power - kW (HP)	5.5 (7.4)
Operating Speed (rpm)	2600
Fuel Type	Diesel
Drive	Hydrostatic
Travel Speed (kph)	3.2
Braking System - Service	Dynamic Hydrostatic
Braking System - Parking	Spring Apply / Hydraulic Release

Capacities

	MBR71
Hydraulic Tank Capacity (litres)	7.5
Fuel Tank Capacity (litres)	5
Water Tank Capacity (litres)	20

Standard Equipment & Options

Standard Equipment

Gravity Fed Water System
Drum Scraper Bars Front and Rear (both drums on 2-65)
Removable plastic water and oil tanks for easy servicing (2-65 only)
Low maintenance battery
Emergency Release Free Wheel Valve (for Towing)
Integral lifting points
Vandal Protection Package - Lockable instrument cover to deter vandals / thieves

Optional Equipment

Hydraulic Breaker attachment, tool, valve and hosing - 30 l/min
Tow behind trailer with breaker storage box
Electric starting with Hour Meter

Dealer



Mill Street
 Radcliffe
 Manchester
 M26 1AJ
 Tel: 0161 959 0000 | Fax: 0161 959 1111 | Email: hire@pjpuk.com



TEREX Construction
 Central Boulevard, ProLogis Park,
 Coventry, England CV6 4BX

PHONE ++44 (0) 2476 339400
 FAX ++44 (0) 2476 339500
 EMAIL enquiries@terexce.com
 WEB www.terexce.com

www.terex.com

For further information, please contact your local distributor or the Terex sales office listed. Terex pursues a policy of continuous development for its products. Product specifications are subject to change without notice or obligation. The photographs and drawings in this brochure are for illustrative purposes only. Refer to the appropriate Operator's Manual for instructions on the proper use of this equipment. Failure to follow the appropriate Operator's Manual when using our equipment or to otherwise act irresponsibly may result in serious injury or death. Prices and specifications subject to change without notice. The only warranty applicable is the standard written warranty applicable to the particular product and sale. Terex makes no other warranties, whether expressed or implied. Products and services listed may be trademarks, service marks or trade-names of Terex Corporation and/or its subsidiaries in the USA and other countries and all rights are reserved. "Terex" is a Registered Trademark of Terex Corporation in the USA and many other countries. Copyright ©09.2006 Terex Corporation

RS PED 0107-EN



Printed on material using 55% recycled fibre from both pre and post-consumer sources, together with 45% virgin ECF fibre from sustainable forests.